



suzukimarine.com

SUZUKI MARINE

OUTBOARD MOTORS

FULL LINE CATALOG



CONTENTS

4-5 **CLEAN OCEAN PROJECT**

6-11 **SUZUKI ULTIMATE TECHNOLOGY**

12-13 **STEALTH LINE® SERIES**

DF350 STEALTH
DF300AP STEALTH
DF250A / 250 / *225 STEALTH
DF200A / *200AP / 150A STEALTH
DF140B / *140BG / 115B STEALTH
*DF25A / *DF9.9B STEALTH

14-15 **GEKI: 350-300HP FLAGSHIP**

DF350AMD/300BMD
DF350A/300B

16-17 **V6 300-200HP**

DF300AP/250AP
*DF250/225/200

18-19 **IN-LINE 4 200-150HP**

DF200AP/175AP/150AP
DF200A/175A/150A

20-21 **IN-LINE 4 140-75HP**

DF140BG/115BG
DF140B/115B
DF90A/75A

22-23 **IN-LINE 3 60-25HP**

DF60AV/50AV
DF60A/50A/40A
DF30A/25A

24-25 **PORTABLE 20-2.5HP**

DF20A/15A/9.9B
DF6A/4A
DF2.5

26-31 **SPECIFICATIONS & FEATURES**

Suzuki Marine USA, LLC
13521 Prestige Pl.
Tampa, FL 33635-2529
www.suzukimarine.com

FULL LINE CATALOG
99953-26501
Printed in the U.S.A.
PV052026

*** NEW**

©2026 Suzuki Marine USA, LLC. All rights reserved.



**A RELIABLE PARTNER
FOR WORK AND PLEASURE
ON THE WATER**



CLEAN OCEAN PROJECT

Since 2020, Suzuki's Clean Ocean Project has focused on reducing marine plastic waste through three commitments: Clean-up the World Campaign, Reduce Plastic Packaging and Collect Marine Micro-plastic Waste.

Together we can make a difference for cleaner, healthier oceans.

CLEAN-UP THE WORLD CAMPAIGN

As of June 2025 More than 23,500 people from 95 groups participated in this activity.



BRAZIL



CHINA



COLOMBIA



KUWAIT



MEXICO



PAKISTAN



POLAND



THAILAND



USA

REDUCE PLASTIC PACKAGING

As part of our commitment to environmental sustainability, we are progressively replacing plastic packaging used for outboard motors and genuine marine parts with eco-conscious, sustainable alternatives—aiming to reduce plastic waste and minimize our environmental footprint.

PACKAGING FOR SUZUKI OUTBOARD MOTORS
REDUCED PLASTIC PACKAGING - 92.1 TONS (as of June 2025)

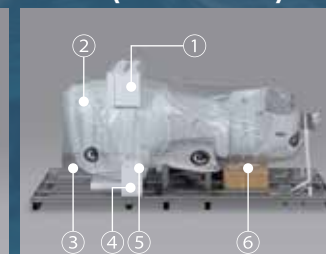
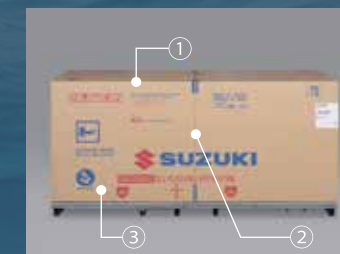

- ① **OPP Tape**
Polypropylene → Paper
- ② **Outer Fixing Band**
Polypropylene → Paper
- ③ **Ink (for all the ink on the carton)**
Animal-derived ink → Botanical Ink
- ④ **Fixing Form**
Polystyrene Foam → 100% biomass-derived polymers
- ⑤ **Upper Engine Cover Sheet**
Nylon → Rayon
- ⑥ **Engine Cover Sheet**
Polyethylene → 100% biomass-derived polymers
- ⑦ **Inner Fixing Band**
Polypropylene → Paper



Plastic Packaging



Paper & Biodegradable Materials

TOTAL REDUCTION 128.0 Ton

COLLECT MARINE MICRO-PLASTIC WASTE

In response to the growing issue of plastic pollution in our oceans, Suzuki has developed the world's first Micro-Plastic Collecting (MPC) device designed for integration with outboard motors.

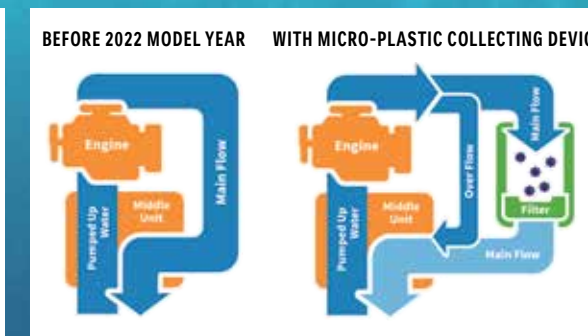
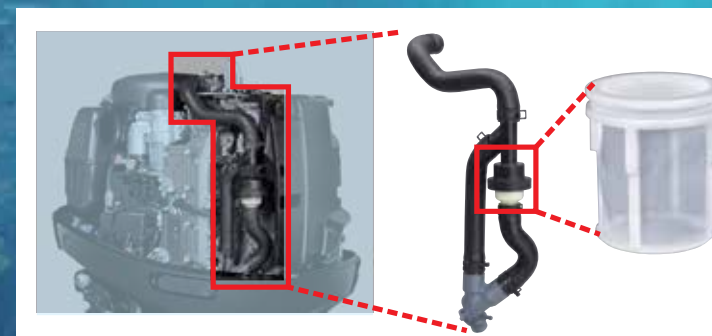

FEATURES

- Will not affect the performance of the engine even if the filter gets clogged since this device utilizes the used cooling water.
- Will not have negative effects on the environment.



DF140BG
DF115BG

SUZUKI PRECISION CONTROL (S.P.C.) 2.0 with MPC

STANDARD EQUIPMENT ON

DF140BG / 115BG
DF140B / 115B

DF140B
DF115B

MECHANICAL with MPC



LEADING THE INDUSTRY WITH AWARD WINNING TECHNOLOGIES AND DESIGNS, SUZUKI OUTBOARDS PROVIDE FEATURES AND BENEFITS THAT MAKE BOATING EVEN MORE ENJOYABLE

Durability & Reliability	Performance	Ease & Comfort	Ecology & Economy
<ul style="list-style-type: none"> • Durable • Notifies user before engine trouble • Easy to service and repair <div style="display: flex; flex-wrap: wrap; justify-content: space-around;"> <div style="text-align: center; margin: 5px;"> DUAL LOUVER</div> <div style="text-align: center; margin: 5px;"> WATER DETECTING SYSTEM</div> <div style="text-align: center; margin: 5px;"> SELF-ADJUSTING TIMING CHAIN</div> <div style="text-align: center; margin: 5px;"> TILT LIMIT</div> <div style="text-align: center; margin: 5px;"> ANTI CORROSION</div> <div style="text-align: center; margin: 5px;"> DUAL WATER INLET</div> <div style="text-align: center; margin: 5px;"> SUZUKI SDSM</div> <div style="text-align: center; margin: 5px;"> SUB WATER INLET</div> <div style="text-align: center; margin: 5px;"> SDSM+</div> </div>	<ul style="list-style-type: none"> • Smooth and quick acceleration at all operating ranges • Powerful torque <div style="display: flex; flex-wrap: wrap; justify-content: space-around;"> <div style="text-align: center; margin: 5px;"> OFFSET DRIVESHAFT</div> <div style="text-align: center; margin: 5px;"> DUAL PROP</div> <div style="text-align: center; margin: 5px;"> MULTI-STAGE INDUCTION</div> <div style="text-align: center; margin: 5px;"> 2.50 GEAR RATIO</div> <div style="text-align: center; margin: 5px;"> HIGH ENERGY ROTATION</div> <div style="text-align: center; margin: 5px;"> VVT VARIABLE VALVE TIMING</div> <div style="text-align: center; margin: 5px;"> DIRECT INTAKE</div> </div>	<ul style="list-style-type: none"> • Less vibration • Quiet operation • Light & compact • Easy to use • Smooth and decisive shifting <div style="display: flex; flex-wrap: wrap; justify-content: space-around;"> <div style="text-align: center; margin: 5px;"> SELECTIVE ROTATION</div> <div style="text-align: center; margin: 5px;"> QUIET OPERATION</div> <div style="text-align: center; margin: 5px;"> PRECISION CONTROL</div> <div style="text-align: center; margin: 5px;"> THREE-WAY STORAGE</div> <div style="text-align: center; margin: 5px;"> OVERHEAD TANK</div> <div style="text-align: center; margin: 5px;"> TROLL MODE</div> <div style="text-align: center; margin: 5px;"> INTEGRATED STEERING SYSTEM</div> <div style="text-align: center; margin: 5px;"> EASY START SYSTEM</div> <div style="text-align: center; margin: 5px;"> AUTOMATIC TRIM</div> </div>	<ul style="list-style-type: none"> • Good fuel efficiency / low exhaust emissions • Low maintenance cost • Environmental protection activities <div style="display: flex; flex-wrap: wrap; justify-content: space-around;"> <div style="text-align: center; margin: 5px;"> LEAN BURN</div> <div style="text-align: center; margin: 5px;"> DUAL INJECTOR</div> <div style="text-align: center; margin: 5px;"> LESS BATTERY-LESS FUEL INJECTION</div> <div style="text-align: center; margin: 5px;"> CLEAN OCEAN PROJECT</div> </div>

Durability & Reliability



SUZUKI DUAL LOUVER SYSTEM

▶DF350AMD/300BMD ▶DF350 STEALTH ▶DF350A/300B

Dog-leg shaped dual louvers remove water droplets & spray from the air directed into the cowling.

ADVANTAGE

- Prevents water intrusion.
- Allows a direct intake system, contributing to higher engine output.



SELF-ADJUSTING TIMING CHAIN

▶DF40A AND UP

The timing chain running in an oil-bath is adjusted automatically by hydraulic tensioner.

ADVANTAGE

- More durable than the belt type.
- Maintenance-free.



DUAL WATER INLET

▶DF350AMD/300BMD ▶DF350 STEALTH ▶DF350A/300B
▶DF300AP/250AP ▶DF300STEALTH ▶DF250A/250 STEALTH

The engine's cooling system relies on water supplied through two water inlets located on the lower unit.

ADVANTAGE

- Increases the water flow, providing better cooling performance.



WATER DETECTING SYSTEM

▶DF75A AND UP

A water detecting fuel filter system. When water is detected, the system will alert the driver with visual and audio warnings.

ADVANTAGE

- Helps prevent lower power output and corrosion by alerting driver of water intrusion.



TILT LIMIT SYSTEM

▶DF50AV AND UP
(not including DF50A/40A)

Tilt Limit System prevents the outboard from tilting beyond a selected angle.

ADVANTAGE

- Prevents damage to the boat or outboard due to excessive outboard tilting.

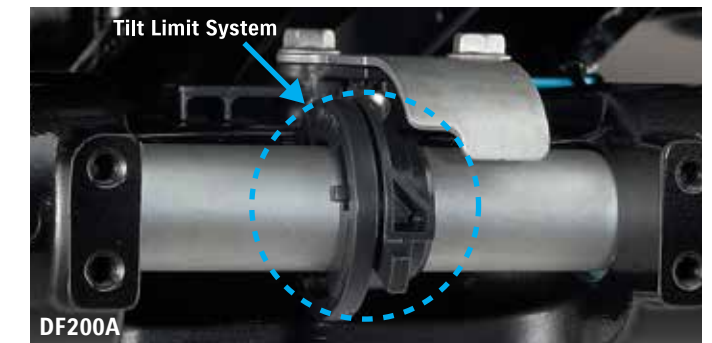

SUB WATER INLET

STANDARD: ▶DF60A/50A/40A

Two water inlets in different directions ensure that the engine does not overheat due to clogging by sea grass or algae.

NMMA Innovation Awards

The Innovation Awards (recognizing technological innovation) awarded each year by the NMMA (National Marine Manufacturers Association) are considered among the highest honor in marine technology. Of the new marine industry products in that year, they are awarded to "a product that shows technical leadership, is practical and cost-effective, and is truly beneficial to the consumer."

Starting with the DT200 Exanté in 1987 and extending to the DF350A in 2017, Suzuki outboard motors have received this Innovation Award a total of nine times. Eight of these awards are for 4-stroke outboard motors.



Awarded Prizes

1987: DT200 Exanté	2011: DF50A & DF40A
1997: DF70 & DF60	2012: DF300AP
1998: DF50 & DF40	2014: DF30A & DF25A
2003: DF250	2017: DF350A
2006: DF300	



KEYLESS START SYSTEM

OPTIONAL: ▶ DF350AMD/300BMD ▶ DF350 STEALTH ▶ DF350A/300B
▶ DF300AP/300 STEALTH/250AP ▶ DF250A/250STEALTH
▶ DF250T/225T/200T ▶ DF200AP/175AP/150AP
▶ DF200A/175A/150A ▶ DF140BG/115BG
▶ DF140B/115B ▶ DF90A/75A

This system allows you to start multiple engines by placing a key-fob nearby.

- One push Start & Stop for up to 6 outboard motors.
- Waterproof Floating Key Fob.
- Security support with immobilizer.

ADVANTAGE

- Provides high security.
- Ignition key is not required.



SDSM+ (SUZUKI DIAGNOSTIC SYSTEM MOBILE+)

▶ DF9.9B AND UP*

Use the app to plan for boating by checking the weather forecast, the engine condition and operation tips. All functions are available for free.* Please check our website for more details.

*SMD/SMG4 and a smartphone running Android/iOS are required.

ADVANTAGE

- Possible to make a plan for boat trip by checking the weather forecast in advance.
- Check up on the engines before the departure based on the engine data.
- Acquire the engine data by scanning the QR code*.
- Provide the engine data to dealer and ask for maintenance easily.

*DENSO WAVE owns the rights of the name and the logo of QR code.



SUZUKI ANTI-CORROSION FINISH

▶ ALL MODELS

Special protection is applied to the aluminum surface using high strength bonding to protect the aluminum made exterior parts.

ADVANTAGE

- Protection against corrosion helps increase the overall outboard durability.

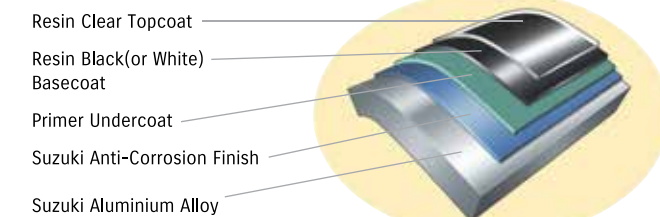

HIGH ENERGY ROTATION

▶ DF60AV/50AV

A larger lower unit (2.42 gear ratio) makes it possible to equip larger 36cm (14-inch) propeller than other models in this class. It offers better acceleration and more power.

ADVANTAGE

- Powerful torque to carry heavy loads.
- Quick acceleration with larger propellers.
- Quick and smooth planing.

DF60AV vs. DF60A size comparison

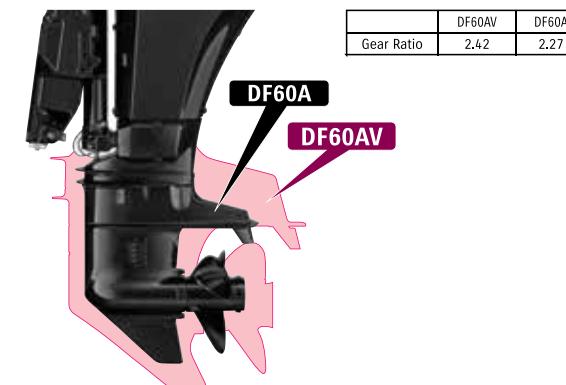

MULTI-STAGE INDUCTION

▶ DF250A/250 STEALTH ▶ DF250/225
▶ DF200AP/175AP/150AP ▶ DF200A/175A/150A

Intake manifold pipes are switched between short and long during low speed and high speed operation to ensure the right volume of air enters the engine.

ADVANTAGE

- Increases output during high speed operation with greater volume of air input.
- Increases combustion efficiency and maximizes torque during low speed operation.

AIR FLOW IN MULTI-STAGE INDUCTION MODULE

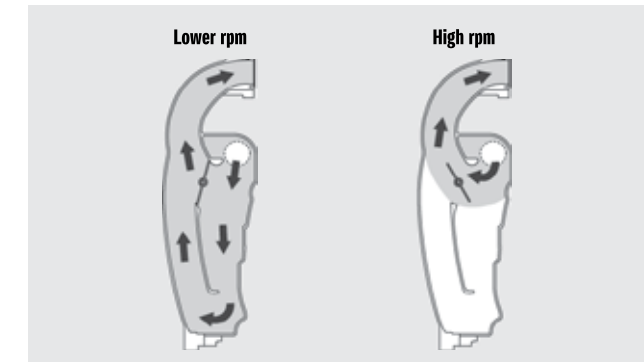

DIRECT AIR INTAKE

▶ DF350AMD/300BMD ▶ DF350 STEALTH ▶ DF350A/300B

A direct airflow path from the intake port to the cylinder suppresses temperature rise of the air and improves combustion efficiency.

ADVANTAGE

- Delivers higher power output from a small displacement.



SUZUKI DUAL PROP SYSTEM

▶ DF350AMD/300BMD ▶ DF350 STEALTH ▶ DF350A/300B

The Suzuki Dual Prop System spins two propellers rotating in opposite directions on a single lower unit. With the 6 blades, it can get a better grip on the water.

ADVANTAGE

- Achieve superior stability when driving straight.
- Powerful reverse thrust and braking force.
- Good water gripping performance and quick holeshot acceleration.

Performance



OFFSET DRIVESHAFT

▶ DF75A AND UP

The engine powerhead is positioned closer to the front, moving the outboard's center of gravity forward.

ADVANTAGE

- Less vibration
- More compact
- Stable steering performance

1st Stage Reduction : 30:36=1.20
2nd Stage Reduction : 12:25=2.08

Total : 2.50:1

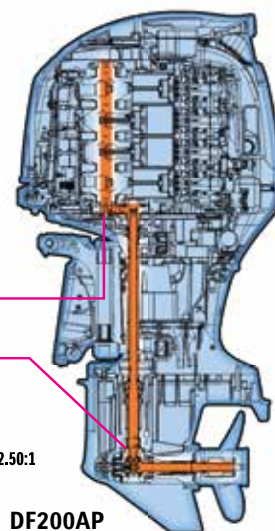

DF200AP



2-STAGE GEAR REDUCTION

▶ DF75A AND UP

This design makes a lower gear ratio possible, allowing it to turn a larger diameter higher pitch propeller.

ADVANTAGE

- Increased power to turn large diameter propellers, offering quick acceleration.
- High propulsive efficiency with large diameter propeller.
- Powerful navigation, maintaining propeller rotation even with a larger load.

GEAR RATIO IN EACH CLASS

MODEL	DF140BG/115BG DF140B/115B 90A/75A	DF200A(AP)/ 175A(AP)/150A(AP)	DF250/ 225/200	DF300AP/250AP DF300AP STEALTH DF250A DF250 STEALTH	DF350AMD/ 300BMD DF350 STEALTH DF350A/300B
GEAR RATIO	2:59:1	2:50:1	2:29:1	2:08:1	2:29:1



VVT (Variable Valve Timing)

▶ DF350AMD/300BMD ▶ DF350 STEALTH ▶ DF350A/300B
▶ DF300AP/250AP ▶ DF300 STEALTH ▶ DF250A/250 STEALTH
▶ DF200AP/175AP/150AP ▶ DF200A/175A/150A

The Variable Valve Timing controls the opening and closing timing of the intake valves depending on the engine RPM.

ADVANTAGE

- Offers smooth, powerful torque.
- Provide smooth acceleration across all speed ranges.

TORQUE CURVE

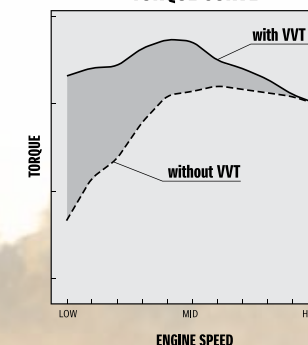

Ease & Comfort



SUZUKI SELECTIVE ROTATION

▶DF300AP/250AP ▶DF300 STEALTH ▶DF200AP/175AP/150AP

Function for selecting regular or counter rotation on one outboard with an optional connector and a counter rotation propeller.

ADVANTAGE

- Either regular or counter rotation can be used on the same outboard.



THREE-WAY STORAGE

▶DF6A/4A

The design allows the outboard to be removed from the boat and placed on any of its 3 sides for storage.

ADVANTAGE

- No need to worry about the loading space or method.



SUZUKI PRECISION CONTROL (S.P.C.) 2.0 (Electronic Throttle and Shift Systems)

▶DF350AMD/300BMD ▶DF350 STEALTH ▶DF350A/300B
▶DF300AP/250AP ▶DF300 STEALTH ▶DF250A STEALTH
▶DF200AP/175AP/150AP ▶DF140BG/115BG

Operation from the remote control is delivered to the outboard via an electric signal and it enables 1 lever operation for up to 6 outboard motors (for Dual Top Mount only).

ADVANTAGE

- Reduced friction and resistance compared to the mechanical controls.
- Easy control for multiple outboard motors.
- Improved fuel economy with the combination of Lean Burn Control System.



OVERHEAD TANK

▶DF6A/4A/2.5

The integral overhead fuel tank and one-way valve delivers fuel supply by using gravity.

ADVANTAGE

- Contributes to easy start.



AUTOMATIC TRIM*

▶ 115HP and Up

The Auto Trim feature adjusts the trim angle automatically depending on the engine RPM.

NOTE

- Requires SMG4 to activate.
- Auto trim is only available on SPC 2.0 engines or 2023 and newer mechanical engines (75hp and up) with CanBus harness.



NOISE REDUCTION

▶DF350AMD/DF300BMD ▶DF350 STEALTH ▶DF350A/300B
▶DF200AP/175AP/150AP ▶DF200A/175A/150A
▶DF140BG/115BG ▶DF140B/115B

Intake noise is reduced with silencer and resonator.

ADVANTAGE

- Less noise, makes boating more enjoyable.

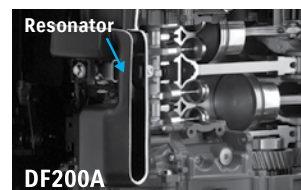

SUZUKI TROLL MODE SYSTEM*

▶DF40A AND UP
Optional for Remote Control Models

This system helps the boat running at a certain speed range in low RPM.

ADVANTAGE

- Boat can keep running at a certain speed range in low RPM without manually having to operate the throttle on the boat.
- Gives you precise control at low RPM.

*Available with SMD, SMG4, or Troll Mode Switch Panel



SUZUKI EASY START SYSTEM

▶DF40 AND UP

Simply turn the key and release, and the starter stays engaged until the engine starts. This system offers a smoother start of the engine.



INTEGRATED STEERING SYSTEM

▶DF350AMD/300BMD ▶DF350 STEALTH

The conventional external hydraulic cylinder is built into the outboard motor.

ADVANTAGE

- Simple appearance of the motorwell when rigging.
- Allows rigging to various types of boats.
- Easy rigging.

Ecology & Economy



BATTERY-LESS ELECTRONIC FUEL INJECTION

▶DF30A/25A ▶DF20A/15A/9.9B

This technology delivers quicker start, smoother operation, and more acceleration without a battery.

ADVANTAGE

- Operates without battery.
- Quick and easy start.
- Cleaner and economic fuel consumption.
- Higher and smoother performance in almost all operating ranges.



DUAL INJECTOR

▶DF350AMD/300BMD ▶DF350 STEALTH ▶DF350A/300B

The dual injectors deliver just the right amount of fuel at just the right time into each cylinder.

ADVANTAGE

- Contributes to higher output and better fuel efficiency.



LEAN BURN CONTROL SYSTEM

LEAN BURN

▶DF9.9B AND UP
(not including V6 DF250/225/200)

The Lean Burn Control System supplies the appropriate amount of fuel and air mixture depending on the running conditions.

ADVANTAGE

- Significant improvement in fuel economy at midrange speeds.
- Fuel is saved and gasoline costs are lowered.

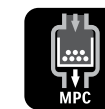

MICRO-PLASTIC COLLECTING DEVICE

▶DF140BG/115BG ▶DF140B/115B ▶DF140B/115B STEALTH

As one of the actions in SUZUKI'S CLEAN OCEAN PROJECT, we developed the device to collect micro-plastics in the oceans just by running a SUZUKI outboard motor.

ADVANTAGE

- Collect micro-plastics through your outboard motors.
- No sacrifice to the engine performance.

STEALTH LINE®



DF350

DF300AP

DF250A
ALSO AVAILABLE IN
STEALTH WHITE

DF250

DF225 **NEW**



NEW **DF200AP** **DF150A**
DF200A

NEW **DF140BG** **DF115B**
DF140B

NEW **DF25A**
NEW **DF9.9B**

**BOLD
QUIET
STYLISH**

SUZUKI PRECISION CONTROL (S.P.C.) 2.0

MECHANICAL

DF350 **DF300AP** **DF250A**
DF200AP **DF140BG**

DF250 **DF225** **DF200A** **DF150A**
DF140B **DF115B** **DF25A** **DF9.9B**

The bold STEALTH LINE® from Suzuki Marine - a range of outboard motors defined by quiet power, exceptional endurance, and now, striking design. With a sleek matte black finish, chrome black graphics, and refined styling that blends renowned Suzuki performance with a commanding new look. Recognized with the 2024 Top Products Award by Boating Industry Magazine, the STEALTH LINE® proves why Suzuki remains the ULTIMATE choice in outboard motors.

Durability & Reliability

- ANTI CORROSION** ALL MODELS
- DUAL LOUVER** DF350AMD
- DUAL WATER INLET** DF350AMD, DF300AP, DF250
- SELF-ADJUSTING TIMING CHAIN** ALL MODELS *3
- WATER DETECTING SYSTEM** ALL MODELS *3
- TILT LIMIT** ALL MODELS *3
- KEYLESS START SYSTEM** (OPTIONAL *1,3)
- SDSM+** (OPTIONAL *1,3)

Ecology & Economy

- DUAL INJECTOR** DF350AMD
- LEAN BURN** ALL MODELS *4
- MPC** DF140B, DF140BG, DF115B

Performance

- 2.29 GEAR RATIO** DF350AMD, DF225
- 2.08 GEAR RATIO** DF300AP, DF250A, DF9.9
- OFFSET DRIVESHAFT** ALL MODELS *3
- DUAL PROP** DF350AMD
- VVT VARIABLE VALVE TIMING** DF350AMD, DF300AP, DF250, DF200A
- 2.50 GEAR RATIO** DF200A, DF200AP, DF150A
- 2.59 GEAR RATIO** DF140B, DF140BG, DF115B
- 2.09 GEAR RATIO** DF25A
- MULTI-STAGE INDUCTION** DF250, DF225, DF200A, DF200AP, DF150A

Ease & Comfort

- SELECTIVE ROTATION** DF300AP, DF200AP
- PRECISION CONTROL** DF350AMD, DF300AP, DF250A, DF200AP, DF140BG
- TROLL MODE** (OPTIONAL *2,3)
- NOISE REDUCTION** ALL MODELS *3,4
- INTEGRATED STEERING SYSTEM** DF350AMD
- AUTOMATIC TRIM** (OPTIONAL *2,3)
- EASY START SYSTEM** ALL MODELS *3

*1 Available with SMG4
*2 Available with SMG4, or Troll Mode Switch Panel
*3 Not available with DF25A or DF9.9B
*4 Not available with DF250 or DF225

SPECIFICATIONS / FEATURES **P26**



SUZUKI DUAL LOUVER SYSTEM P7

Dual Louver system is equipped at the air intake to remove water from the air taken into the cowl. Incorporating a direct intake system makes the highest compression ratio of 12.0:1 (DF350AMD, DF350A), 10.5:1 (DF300BMD, 300B) possible, ultimately leading to a higher engine output.



SUZUKI DUAL PROP SYSTEM P9

The dual prop system efficiently transmits the horsepower output into propulsion under water. As an added benefit, because each propeller rotates in a different direction, exceptional stability is achieved. In addition, the contra-rotating propellers produce a strong reverse thrust.

GEKI FLAGSHIP SERIES

A Force to Match the Power of Nature and the Sea Representing Suzuki's Identity and Heritage. A Symbol of Our Passion and Commitment to the the Ultimate in Marine Innovation

* "GEKI: PARTING SEAS" is the logo that represents the DF350AMD/DF300BMD, DF350A/DF325A/DF300B



DUAL WATER INLET P7

The engine's cooling system relies on water supplied through low water intakes located on the lower unit. This dual water inlet configuration increases water flow into the lower unit, delivering greater cooling efficiency.



DUAL INJECTOR P11

Dual injectors deliver just the right amount of fuel at just the right time into the cylinder. This dual injector contributes to higher output and better fuel efficiency.

SUZUKI PRECISION CONTROL (S.P.C.) 2.0

DF350AMD/ DF300BMD



DF350A/DF300B

Durability & Reliability

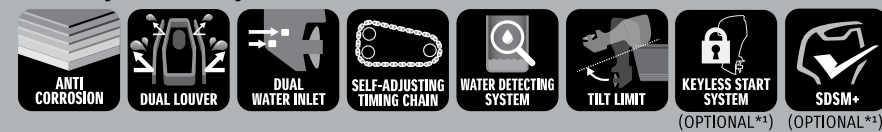

Ecology & Economy

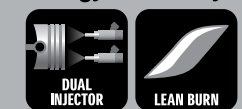

Performance

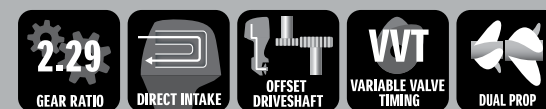

Ease & Comfort

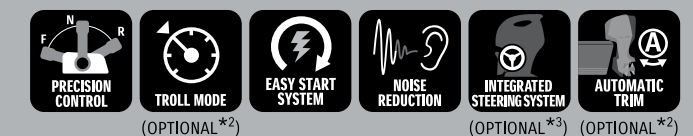

*1 Available with SMG4

*2 Available with SMG4, or Troll Mode Switch Panel

*3 DF350AMD/300BMD

SPECIFICATIONS / FEATURES P28

Flagship-GEKI SERIES

V6 300-200HP

IN-LINE 4, 200-150HP

IN-LINE 4, 140-70HP

IN-LINE 3 60-25HP

PORTABLE 20-2.5HP



NEW
DF250

MECHANICAL DF225/DF200



NEW
DF300AP
DF250AP

SUZUKI PRECISION CONTROL (S.P.C.) 2.0



STANDARD FEATURES

Durability & Reliability

ANTI CORROSION ALL MODELS	SELF-ADJUSTING TIMING CHAIN ALL MODELS	WATER DETECTING SYSTEM ALL MODELS	TILT LIMIT ALL MODELS	SDSM+ (OPTIONAL*1) ALL MODELS
------------------------------	---	--------------------------------------	--------------------------	-------------------------------------

Performance

2.29 GEAR RATIO DF250 DF225 DF200	2.08 GEAR RATIO DF300AP DF250AP	OFFSET DRIVESHAFT ALL MODELS	VVT VARIABLE VALVE TIMING DF300AP DF250AP DF250	MULTI-STAGE INDUCTION DF250 DF225
--	---	---------------------------------	---	---

ADDITIONAL FEATURES FOR DRIVE BY WIRE MODEL

Durability & Reliability

DUAL WATER INLET DF300AP DF250AP	KEYLESS START SYSTEM (OPTIONAL*1) ALL MODELS
--	--

Ease & Comfort

SELECTIVE ROTATION DF300AP DF250AP	PRECISION CONTROL DF300AP DF250AP	TROLL MODE (OPTIONAL*2) ALL MODELS	EASY START SYSTEM ALL MODELS	AUTOMATIC TRIM (OPTIONAL*2) ALL MODELS
--	---	--	---------------------------------	--

Ecology & Economy

LEAN BURN DF300AP DF250AP

*1 Available with SMG4

*2 Available with SMG4, or Troll Mode Switch Panel

Flagship-GEKI SERIES
VG 300-200HP
IN-LINE 4 200-150HP
IN-LINE 4 140-70HP
IN-LINE 3 60-25HP
PORTABLE 20-2.5HP



DF200AP
DF175AP / DF150AP
SUZUKI PRECISION CONTROL (S.P.C.) 2.0

DF200A
DF175A / DF150A
MECHANICAL

STANDARD FEATURES

Durability & Reliability

- ANTI CORROSION**
ALL MODELS
- SELF-ADJUSTING TIMING CHAIN**
ALL MODELS
- WATER DETECTING SYSTEM**
ALL MODELS
- TILT LIMIT**
ALL MODELS
- SDSM+**
(OPTIONAL*1)
ALL MODELS
- KEYLESS START SYSTEM**
(OPTIONAL*1)
ALL MODELS

Performance

- OFFSET DRIVESHAFT**
ALL MODELS
- 2.50 GEAR RATIO**
ALL MODELS
- MULTI-STAGE INDUCTION**
ALL MODELS
- VVT VARIABLE VALVE TIMING**
Not including DF150A

Ease & Comfort

- NOISE REDUCTION**
ALL MODELS
- TROLL MODE**
(OPTIONAL*2)
ALL MODELS
- EASY START SYSTEM**
(OPTIONAL*2)
ALL MODELS
- AUTOMATIC TRIM**
(OPTIONAL*2)
ALL MODELS

Ecology & Economy

- LEAN BURN**
ALL MODELS

ADDITIONAL FEATURES FOR SUZUKI PRECISION CONTROL 2.0

Ease & Comfort

- SELECTIVE ROTATION**
DF200AP
DF175AP
DF150AP
- PRECISION CONTROL**
DF200AP
DF175AP
DF150AP

*1 Available with SMG4 *2 Available with SMG4, or Troll Mode Switch Panel

SPECIFICATIONS / FEATURES **P29**

Flagship-GEKI SERIES
 V6 300-200HP
 IN-LINE 4 200-150HP
 IN-LINE 4 140-70HP
 IN-LINE 3 60-25HP
 PORTABLE 20-2.5HP



DF140BG

DF115BG
SUZUKI PRECISION CONTROL (S.P.C.) 2.0

with MPC

DF140B

DF115B
MECHANICAL

with MPC



**DF90A
DF75A**
MECHANICAL

STANDARD FEATURES

Durability & Reliability

- ANTI CORROSION (ALL MODELS)
- SELF-ADJUSTING TIMING CHAIN (ALL MODELS)
- WATER DETECTING SYSTEM (ALL MODELS)
- TILT LIMIT (ALL MODELS)
- SDSM+ (OPTIONAL*2) (ALL MODELS)
- SUB WATER INLET (OPTIONAL) (ALL MODELS)
- KEYLESS START SYSTEM (OPTIONAL*1) (ALL MODELS)

Ease & Comfort

- TROLL MODE (OPTIONAL*2) (REMOTE CONTROL MODELS (STANDARD) (TILLER HANDLE MODELS))
- EASY START SYSTEM (ALL MODELS)
- NOISE REDUCTION (DF140BG/DF115BG (DF140B/DF115B))
- AUTOMATIC TRIM (OPTIONAL*2) (DF140BG/115BG (DF140B/115B))
- OFFSET DRIVESHAFT (ALL MODELS)

Performance

Ecology & Economy

- GEAR RATIO 2.59 (ALL MODELS)
- LEAN BUR (ALL MODELS)
- MPC (DF140BG/DF115BG (DF140B/DF115B))

ADDITIONAL FEATURES AVAILABLE FOR SUZUKI PRECISION CONTROL (S.P.C.) 2.0

Ease & Comfort

- PRECISION CONTROL (DF140BG (DF115BG))
- TILLER HANDLE (OPTIONAL) (DF115B (DF90A (DF75A)))

*1 Available with SMG4
*2 Available with SMG4, or Troll Mode Switch Panel

SPECIFICATIONS / FEATURES P30

Flagship-GEKI SERIES
16 300-200HP
IN-LINE 4 200-150HP
IN-LINE 4 140-70HP
IN-LINE 3 60-25HP
PORTABLE 20-2.5HP



DF60AV

DF50AV

HIGH ENERGY ROTATION





DF60A

DF50A / DF40A



STANDARD FEATURES

Durability & Reliability

 ANTI CORROSION ALL MODELS	 TILT LIMIT ALL MODELS	 SELF-ADJUSTING TIMING CHAIN ALL MODELS	 SDSM+ (OPTIONAL*1) ALL MODELS	 SUB WATER INLET DF60A DF50A DF40A
--	--	---	--	--

Performance

HIGH ENERGY
ROTATION
DF60AV
DF50AV

Ease & Comfort

TROLL MODE
(OPTIONAL*2)
REMOTE CONTROL MODELS
(STANDARD)
TILLER HANDLE MODELS

EASY START
SYSTEM
ALL MODELS

TILLER
HANDLE
(BLACK ONLY)
DF60ATH
DF50ATH
DF40ATH

Ecology & Economy

LEAN BURN
ALL MODELS

*1 Available with SMG4 *2 Available with SMG4, or Troll Mode Switch Panel



DF30A

DF25A

BATTERY-LESS EFI

Power Trim and Tilt Available
Remote Control Model Available

STANDARD FEATURES

Durability & Reliability

 ANTI CORROSION	 SDSM+ (OPTIONAL*1) ALL MODELS
--	--

Ease & Comfort

TILLER
HANDLE
(OPTIONAL)

Ecology & Economy

 LEAN BURN	 LESS BATTERY-LESS FUEL INJECTION
--	---



*1 Available with SMG4

SPECIFICATIONS / FEATURES P30



DF20A

DF15A
DF9.9B

BATTERY-LESS EFI

- Remote control model available
- Power Tilt available
- Electric Start available



DF6A

THREE WAY STORAGE

■ Tiller only



DF4A

THREE WAY STORAGE

■ Tiller only



DF2.5

■ Tiller only

STANDARD FEATURES

Durability & Reliability

- ANTI CORROSION
ALL MODELS
- SDSM+
(OPTIONAL *1)
DF20A
DF15A
DF9.9B

Ease & Comfort

- THREE-WAY STORAGE
DF6A
DF4A
- OVERHEAD TANK
DF6A
DF4A

Ecology & Economy

- LEAN BURN
DF20A
DF15A
DF9.9B
- BATTERY-LESS FUEL INJECTION
DF20A
DF15A
DF9.9B

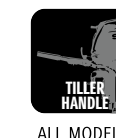

*1 Available with SMG4

SPECIFICATIONS / FEATURES **P31**

SPECIFICATIONS & FEATURES

SPECIFICATIONS	350AMD	300BMD	350A	300B	300AP	250AP	250T	225T	200T
STARTING SYSTEM	Electric		Electric		Electric		Electric		
RECOMMENDED TRANSOM HEIGHT (IN)	L: 20 X: 25 XX: 30		X: 25 XX: 30		L: 20 ² X: 25 XX: 30		X: 25 XX: 30	X: 25	L: 20 X: 25 XX: 30
WEIGHT (LBS) *1	L: 760 X: 776 XX: 793		X: 727 XX: 745		L: 626 ² X: 639 XX: 659		X: 606 XX: 626	X: 606	L: 582 X: 606 XX: 626
VALVE TRAIN	DOHC 24-Valve		DOHC 24-Valve		DOHC 24-Valve		DOHC 24-Valve		
VALVE TRAIN DRIVE	Chain		Chain		Chain		Chain		
DISPLACEMENT	4.4 Liter		4.4 Liter		4.0 Liter		3.6 Liter		
MAXIMUM OUTPUT HP	350	300	350	300	300	250	250	225	200
BORE & STROKE (IN)	3.86 x 3.82		3.86 x 3.82		3.86 x 3.50		3.74 x 3.35		
OPERATION RANGE (RPM)	5,700-6,300	5,300-6,300	5,700-6,300	5,300-6,300	5,700-6,300	5,500-6,100	5,500-6,100	5,000-6,000	5,000-6,000
FUEL DELIVERY SYSTEM	Electronic Fuel Injection		Electronic Fuel Injection		Electronic Fuel Injection		Electronic Fuel Injection		
OIL PAN CAPACITY (QTS)	8.5 (9.0 when changing oil filter)		8.5 (9.0 when changing oil filter)		8.5 (8.7 when changing oil filter)		8.5 (8.7 when changing oil filter)		
SYSTEM OUTPUT	12V 54A		12V 54A		12V 54A		12V 54A		
TRIM TYPE	Power Trim and Tilt		Power Trim and Tilt		Power Trim and Tilt		Power Trim and Tilt		
GEAR RATIO	2.29:1		2.29:1		2.08:1		2.29:1		
CONTROL SYSTEM	Digital		Digital		Digital		Mechanical		
RECOMMENDED FUEL	89 Octane	87 Octane	89 Octane	87 Octane	87 Octane		87 Octane		
PROPELLER SELECTION (PITCH)	12"-31.5"		12"-31.5"		17"-26"		17"-26"		

	200AP	175AP	150AP	200A	175A	150A
STARTING SYSTEM	Electric			Electric		
RECOMMENDED TRANSOM HEIGHT (IN)	L: 20 X: 25			L: 20 X: 25		
WEIGHT (LBS) *1	L: 520 X: 531			L: 518 X: 529		
VALVE TRAIN	DOHC 16-Valve			DOHC 16-Valve		
VALVE TRAIN DRIVE	Chain			Chain		
DISPLACEMENT	2.9 Liter			2.9 Liter		
MAXIMUM OUTPUT HP	200	175	150	200	175	150
BORE & STROKE (IN)	3.82 x 3.82			3.82 x 3.82		
OPERATION RANGE (RPM)	5,500-6,100	5,000-6,000		5,500-6,100	5,000-6,000	
FUEL DELIVERY SYSTEM	Electronic Fuel Injection			Electronic Fuel Injection		
OIL PAN CAPACITY (QTS)	8.5 (9.0 when changing oil filter)			8.5 (9.0 when changing oil filter)		
SYSTEM OUTPUT	12V 44A			12V 44A		
TRIM TYPE	Power Trim and Tilt			Power Trim and Tilt		
GEAR RATIO	2.50:1			2.50:1		
CONTROL SYSTEM	Digital			Mechanical		
RECOMMENDED FUEL	87 Octane			87 Octane		
PROPELLER SELECTION (PITCH)	17"-26"			17"-26"		

FEATURES

	350AMD	300BMD	350A	300B	300AP	250AP	250T	225T	200T
BODY COLOR	Black	●	●	●	●	●	●	●	●
	White	●	●	●	●	●	●	●	●
INTEGRATED STEERING	●	●							
SUZUKI DUAL LOUVER SYSTEM	●	●	●	●					
SELF ADJUSTING TIMING CHAIN	●	●	●	●	●	●	●	●	●
SUZUKI ANTI-CORROSION SYSTEM	●	●	●	●	●	●	●	●	●
OVER-REV. LIMITER	●	●	●	●	●	●	●	●	●
TILT LIMIT SYSTEM	●	●	●	●	●	●	●	●	●
WATER DETECTING SYSTEM	●	●	●	●	●	●	●	●	●
FRESH WATER FLUSHING SYSTEM	●	●	●	●	●	●	●	●	●
DUAL WATER INLET	●	●	●	●	●	●			
SUB WATER INLET									
NEW KEYLESS START SYSTEM	○	○	○	○	○	○	○ ⁶	○ ⁶	○ ⁶
SDSM⁺³	○	○	○	○	○	○	○	○	○
OFFSET DRIVESHAFT	●	●	●	●	●	●	●	●	●
2-STAGE GEAR REDUCTION	●	●	●	●	●	●	●	●	●
HIGH ENERGY ROTATION									
SUZUKI DUAL PROP SYSTEM	●	●	●	●					
VARIABLE VALVE TIMING	●	●	●	●	●	●	●	●	
MULTI-STAGE INDUCTION							●	●	
SUZUKI SELECTIVE ROTATION	●	●	●	●	●	●			
SUZUKI PRECISION CONTROL	●	●	●	●	●	●			
NOISE REDUCTION	●	●	●	●	●	●			
OVERHEAD TANK									
AUTOMATIC TRIM⁴	○	○	○	○	○	○	○ ⁶	○ ⁶	○ ⁶
THREE-WAY STORAGE									
SUZUKI TROLL MODE SYSTEM⁵	○	○	○	○	○	○	○	○	○
SUZUKI EASY START SYSTEM	●	●	●	●	●	●	●	●	●
LEAN BURN CONTROL SYSTEM	●	●	●	●	●	●			
DUAL INJECTOR	●	●	●	●	●	●			
O2 SENSOR FEEDBACK CONTROL SYSTEM	●	●	●	●	●	●			
SHALLOW WATER DRIVE									

	200AP	175AP	150AP	200A	175A	150A
BODY COLOR	Black	●	●	●	●	●
	White	●	●	●	●	●
INTEGRATED STEERING	●	●	●	●	●	●
SUZUKI DUAL LOUVER SYSTEM	●	●	●	●	●	●
SELF ADJUSTING TIMING CHAIN	●	●	●	●	●	●
SUZUKI ANTI-CORROSION SYSTEM	●	●	●	●	●	●
OVER-REV. LIMITER	●	●	●	●	●	●
TILT LIMIT SYSTEM	●	●	●	●	●	●
WATER DETECTING SYSTEM	●	●	●	●	●	●
FRESH WATER FLUSHING SYSTEM	●	●	●	●	●	●
DUAL WATER INLET	●	●	●	●	●	●
SUB WATER INLET						
NEW KEYLESS START SYSTEM	○	○	○	○ ⁶	○ ⁶	○ ⁶
SDSM⁺³	○	○	○	○	○	○
OFFSET DRIVESHAFT	●	●	●	●	●	●
2-STAGE GEAR REDUCTION	●	●	●	●	●	●
HIGH ENERGY ROTATION						
SUZUKI DUAL PROP SYSTEM	●	●	●	●	●	●
VARIABLE VALVE TIMING	●	●	●	●	●	●
MULTI-STAGE INDUCTION						
SUZUKI SELECTIVE ROTATION	●	●	●	●	●	●
SUZUKI PRECISION CONTROL	●	●	●	●	●	●
NOISE REDUCTION	●	●	●	●	●	●
OVERHEAD TANK						
AUTOMATIC TRIM⁴	○	○	○	○ ⁶	○ ⁶	○ ⁶
THREE-WAY STORAGE						
SUZUKI TROLL MODE SYSTEM⁵	○	○	○	○	○	○
SUZUKI EASY START SYSTEM	●	●	●	●	●	●
LEAN BURN CONTROL SYSTEM	●	●	●	●	●	●
DUAL INJECTOR	●	●	●	●	●	●
O2 SENSOR FEEDBACK CONTROL SYSTEM	●	●	●	●	●	●
SHALLOW WATER DRIVE						



All propellers are the 3-blade type. Please contact your local dealer for details on available propellers.

*1: Dry Weight: Including battery cable, not including propeller and engine oil.

*2: DF300AP Only

*3: Available by using with SMG4/SMD

*4: Available on SMG4/SMD with SPC 2.0 or with optional CAN Harness

*5: Available by using with SMD/SMG4/Troll Mode Switch Panel

*6: Available with optional CAN Harness

●=Standard Equip. ○=Optional Equip.

An aerial view of three Suzuki speedboats moving across the water, leaving white wakes. The boats are white with 'SUZUKI' written in large black letters on their sides. The boat in the foreground has four outboard motors, while the others have two. The water is a deep blue-green color.

SUZUKI
MARINE
FULL LINE CATALOG

Please read your Owner's Manual carefully. Remember, boating and alcohol or other drugs don't mix. Always wear a personal flotation device when boating. Please operate your outboard safely and responsibly. Suzuki encourages you to operate your boat safely and with respect for the marine environment. Specifications, appearances, equipment, colors, materials and other items of "SUZUKI" products shown in this catalog are subject to change by manufacturers at any time without notice and they may vary depending on local conditions or requirements. Each model might be discontinued without notice. Please inquire at your local dealer for details of any such changes. Actual body color might differ from the colors in this brochure.